

stertil[®]

DOCK
P R O D U C T S

COMBILOK

The superior
vehicle restraint system



STERIL
SUPERIOR SOLUTIONS BY
QUALITY PEOPLE

Superior solutions by quality people



More reliable, durable, safer and intelligent than other systems

To manage business operations in a responsible manner, a reliable vehicle restraint system is a necessity within all loading bays. The risk of damage caused by accidents during loading and unloading activities increases significantly as a result of tight time constraints. The communication between warehouse staff and drivers (in their cabs) often leaves a lot to be desired. Prematurely driving away from the dock while the lorry is still being loaded or unloaded is not uncommon. The same applies when considering the risk of a docked lorry creeping forwards.

The Stertil Group offers its customers worldwide customised, technologically sophisticated solutions for their heavy-duty lifting requirements and dock equipment, including the best possible service from experienced local partners. These superior solutions are conceived, developed and implemented by a team of specialised professionals with unique experience. Thanks to its 'quality people', its total in-house production process and its international organisation, Stertil is a leading name in the manufacture and supply of dock levellers, dock shelters and other dock equipment.

The unique COMBILOK® from Stertil limits all of these risks and offers many unique safety benefits.

The highly durable tubular structure is simply installed above ground to guide the wheels of an incoming lorry into a central position in front of the dock. The rearmost wheel is then automatically restrained with the touch of a button.

Universal application

Thanks to the wheel block's height of just 330mm, the standard COMBILOK is suitable for lorries of almost every type and size. Lower or higher wheel blocks are also available upon request. This makes the COMBILOK a system



which is extremely versatile. There are also few restrictions when it comes to the installation process, as the entire system is installed above ground. There are no obstacles on the vehicle's route, and there is no contact with moving lorries. It is only the wheels of the lorry which are guided along the sides by the low, round conduits. The underside of the vehicle and the wheel arches remain free at all times.

The most reliable technology

The COMBILOK incorporates the most sophisticated electrical hydraulic technology and few moving parts. The wheel block is operated via a microprocessor and is controlled using a button on the control panel in the building. An integral sensor in the

wheel block accurately determines the position of the rearmost wheel, whereupon the wheel block is automatically extended and the wheel is restrained. The restraint process occurs in approx. 30 seconds regardless of the size and position of the wheel. The COMBILOK is a unique fully automatic device utilised by many multi-national companies supporting increased health and safety requirements.

Acoustic and optical signals

The intelligent COMBILOK software ensures that before the COMBILOK mobilises acoustic and optical signals are activated for 3 seconds and continue whilst positioning. The COMBILOK is designed to reduce the risk of accidents. The restraining

COMBILOK vehicle restraint system



The wheel block applies constant pressure against the wheel to prevent the vehicle from creeping forwards.



No damage to mudguards or side skirts due to the low height of the wheel block.



Acoustic and optical signals.



block is fitted with an emergency stop button which should be manually pressed, which immediately ceases the activation of the COMBILOK. In addition an external red/green traffic light ensures clear visual communication to the driver. The driver will only receive the green light to drive away once the wheel restraint has been fully retracted.

Options

- Lower or higher wheel block
- Safety circuit with leveller and/or dock door
- Inside traffic light for signalling purposes
- External installation of the hydraulic unit
- Special execution to block swap bodies

Restraint process: 30 seconds.

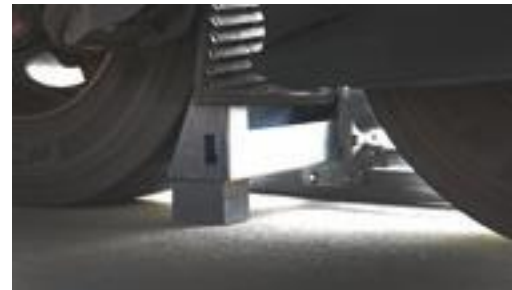

Easy to install above ground.



Increased safety thanks to integrated controls

The control panel has foil push buttons and can be interlocked with other dock systems for example, dock levellers and/or overhead doors. This offers a combined safety circuit. This means that the lorry continues to be automatically restrained until the dock leveller has returned to its idle position.

The green/red lights on the control panel also ensure that within the distribution centre it is clear to see if the vehicle restraint is still in use. After loading or unloading, the COMBILOK can be unlocked with the touch of a button.

Complete programme for superior solutions

For more information on our complete range of Dock products please see our website www.steril.com



Technical specifications

- Galvanised design consisting of strong tubular material and low height of construction with no moving parts below floor level.
- The entire system can be easily accessed for servicing and maintenance purposes.
- Range from platform of 4300mm, working range from wheel block of 2800mm.
- Integrated wheel guides.
- Complete electrical hydraulic operation controlled via a microprocessor.
- Wheel block height of just 330mm; suitable for lorries of almost every type and size.
- Automatic wheel restraint system at the touch of a button in approx. 30 seconds.
- Emergency release possible at all times.
- Simple installation with no civil works required.

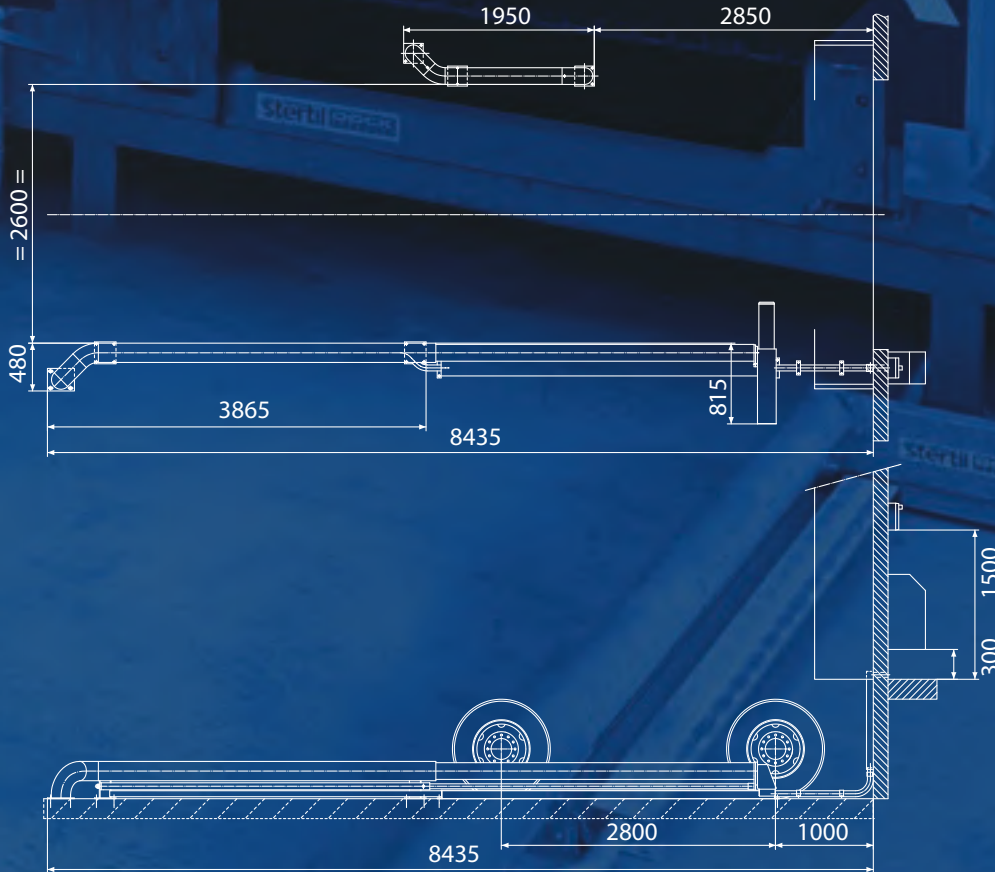

Further information

For further or specific information about the Stertil COMBILOK or any of the other quality products made by Stertil, please contact us. We will be happy to assist you.

Watch our COMBILOK movie here:



Stertil B.V.
P.O.Box 23
9288 ZG Kootstertille
The Netherlands
Tel. +31 (0)512 334444
www.stertil.com
info@stertil.nl
f Stertil Dock Products
@Stertil

 A member of the Stertil Group